

# SurfCleaner<sup>®</sup> SCO 8000

A proven oil skimmer separator hybrid for industrial wastewater treatment.



SurfCleaner SCO 8000 operating in an API separator at a refinery.



# SurfCleaner – the world's first skimmer separator hybrid



## SurfCleaner benefits:

- Automatic removal and separation of oil with 100% separation capability
- Able to handle different types of oil without adjustment, including thin sheens
- Can recover oil with a water content of less than 0.5%
- Capacity to collect and separate up to 8,000 liters of oil per hour
- Continuous operation 24/7 with minimal service requirements, even over long periods of time
- Energy and cost-efficient operation with low maintenance, enabling substantial cost savings
- Easy handling, installation and service
- Quiet operation, ideal for locations in noise sensitive areas
- SCADA-integration
- ATEX/EX certified for Zone 0

## SurfCleaner for oil water separation

More than 30 SurfCleaner units have been in operation for almost two decades in the industrial oil spill segment. We have served a variety of customers, including oil refineries, industries, coast guards and industrial ports, for example: Sonatrach Raffineria Italiana, Exxon Mobil, Preem Refinery, Esso Refinery, Ragn-Sells Group, Swedish Coast Guard, Ports of Stockholm and Midroc Environmental Services.

## Conventional solutions are often manual, inefficient and expensive

Today, a variety of traditional solutions, such as skimmers, barriers, chemicals, etc. are used to collect and/or remove oil in industrial wastewater treatment processes, with varying degrees of efficiency. The majority of solutions do not have the capability to remove thin oil sheens, petrol and diesel.

## SurfCleaner – the Skimmer Separator Hybrid

Automated and highly effective, SurfCleaner represents a solid contribution towards managing the global water surface pollution problem. It is a well-proven, energy efficient system that collects and separates pollutants from water surfaces. Easy to install, run and maintain, SurfCleaner will automatically and continuously separate oil, petrol and diesel from the water surface.

The SurfCleaner technology is based on gravimetric separation, collecting both the carrier fluid and the top layer substance – allowing 100% separation of the top layer substance, with a separation capacity of up to 8,000 liters per hour. Many of our customers that have installed SurfCleaners in their API separator have a more cost effective and efficient solution to removing oil from the water surface.

## Advanced yet simple

SurfCleaner is advanced yet ingeniously simple. The patented collection and separation process has been developed into a self-managing solution consisting of only two moving parts. The separated oil is discharged to an external storage tank. Disposal costs are minimized since the oil is up to 99.5% pure and recyclable.

SurfCleaner has been developed through years of extensive research in close co-operation with customers. In addition to its impressive performance capabilities, it is durable, energy-efficient and easily maintained.

# SurfCleaner SCO 8000

## – facts and information

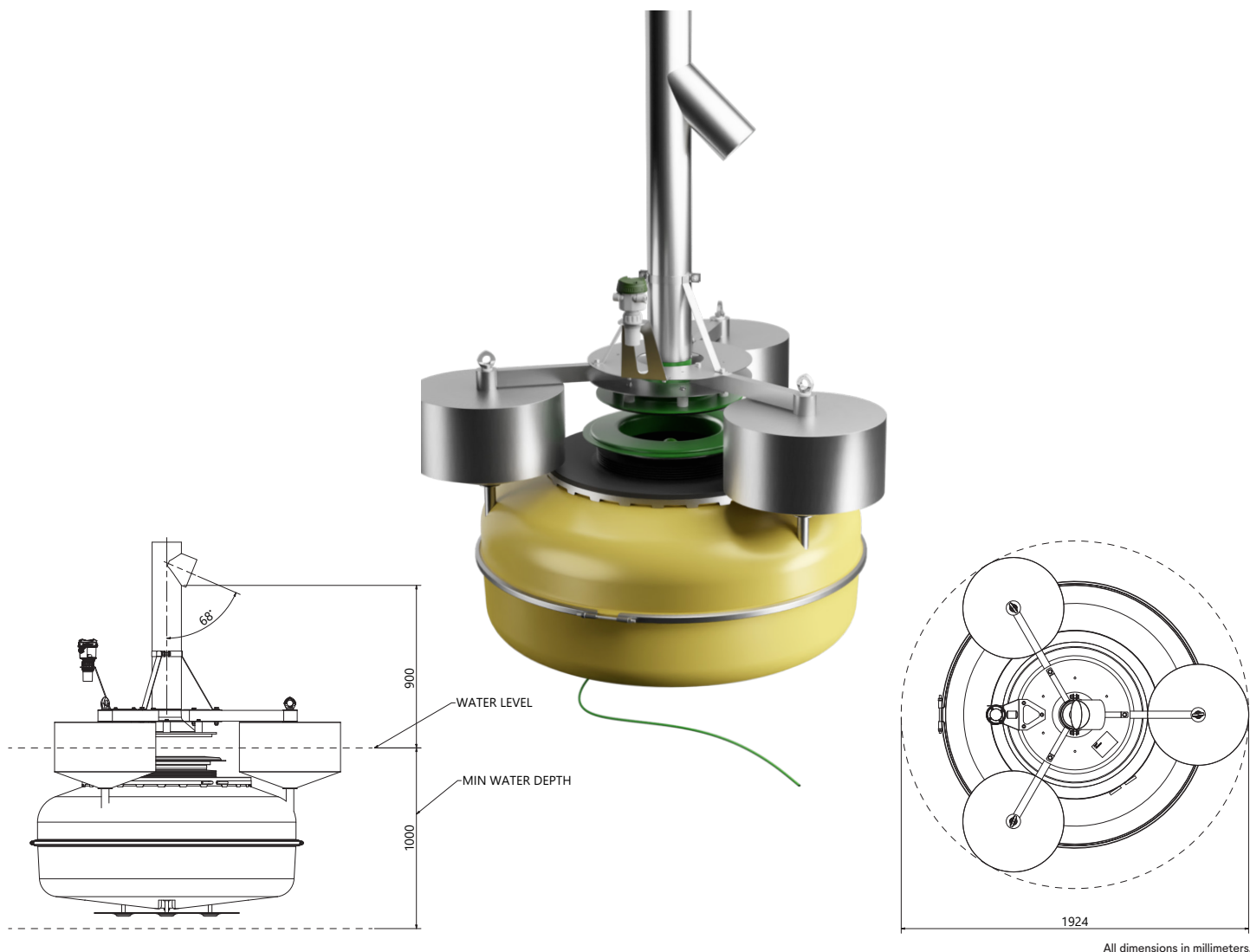

All dimensions in millimeters.

### SurfCleaner SCO 8000 – technical data

#### General

Separation capacity, incl. discharge:	Up to 8,000 liters/h
Viscosity:	Up to 1,000 cP
Density:	0.75 to 0.92 kg/liter
Layer thickness:	> 0.1 µm
Maximum flow discharge:	Up to 50,000 liters/h
Material:	Stainless steel, Polyester
Temperature limit – parts in air	0 to 50° C
Temperature limit – parts in liquid	0 to 40° C (Higher temperatures on special order)

#### Dimensions

Minimum depth:	1,000 mm
Operational diameter:	1,924 m
Weight:	250 kg
Discharge pipe diameter:	160 mm

#### Power and control

Power:	200W average (1,500W peak), three-phase, 400 V, 10 A
Control system:	Siemens Simatic
Motor cable length:	10 m
Sonar cable length:	10 m

#### Options

ATEX/EX:	Zone 0 certificate 
Supervision/SCADA:	Many options available via special order



SurfCleaner®  
is a registered  
trademark.

## About SurfCleaner

SurfCleaner designs, develops and manufactures the world's first hybrid skimmer separators for 100% removal, separation and recovery of contaminants floating on the water surface – oil, diesel, petrol, plastics, sludge, debris, microplastics, algae and more. The SurfCleaner technology is unique; by combining variations in inflow velocity and direction with gravimetric separation, the process is very efficient – keeping pollutants from accumulating on the surface and therefore help minimising greenhouse gas emissions.

The SurfCleaner makes it possible for water treatment plants to solve sludge problems and increase biogas production. We help industries to recover oil, diesel and petrol from contaminated water and reduce CO<sub>2</sub> emissions by up to 95%. We also remove oil in ports, rivers, lakes, mines and oil pits. Future models of SurfCleaner will remove plastics and algae in rivers, ports and coastal areas and make the oceans cleaner.

Customers include Sonatrach Raffineria Italiana, Ragn-Sells Group, Swedish Coast Guard, Preem Refinery, Esso, Exxon Mobil and Ports of Stockholm.

The principle behind the technology is Dr Stig Lundbäck's discovery of the human heart's Dynamic Adaptive Piston Pump (DAPP) functionality. He built on this DAPP technology to invent and develop the SurfCleaner – he also applied other universal laws of physics from the nature and the universe, such as gravity, equilibrium, variation in rotation velocity in the center and the periphery, different density, and more.

This makes the SurfCleaner a truly natural machine, working in concert with the laws of nature, instead of trying to combat them. The natural buoyancy sends the liquid in vertical and horizontal motion inside the body of the SurfCleaner. The SurfCleaner needs no pump, no powerpack, no hydraulics, no pneumatics. That is why the operation of the SurfCleaner is so efficient and cost-effective; we just put the forces of nature to work.

Advanced yet ingeniously simple.

### SurfCleaner's three-step technology:

#### Removal

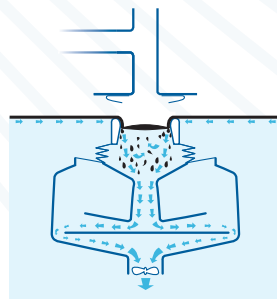

The propeller creates negative pressure, causing the water and pollution to flow into the SurfCleaner.

#### Separation

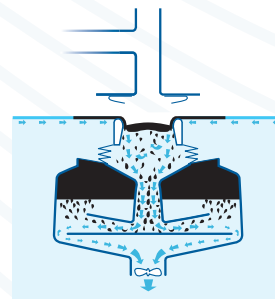

Deflection disks force the pollution and the water to the periphery. As the flow velocity drops, the pollution floats upwards while the water flows down through the outlet.

#### Recovery

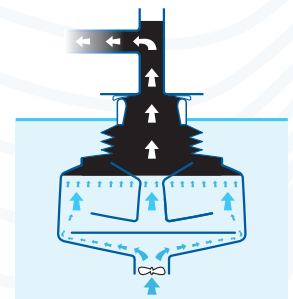

With the water acting as a piston, the pollution is discharged at the rate of up to 8,000 liters per hour into an external container. Recovered oil has a water content of less than 0.5%.

**We are  
the heart  
of water**

**SURF  
CLEANER**

SCO8000-EN-2205  
© SurfCleaner AB 2022

SurfCleaner AB  
Phone: +46 70 515 26 00  
Email: [info@surfcleaner.com](mailto:info@surfcleaner.com)  
Info: [www.surfcleaner.com](http://www.surfcleaner.com)