

# SurfCleaner® SCO 1000

Hybrid skimmer separator for automatic removal, separation, and recovery of oil on water surfaces

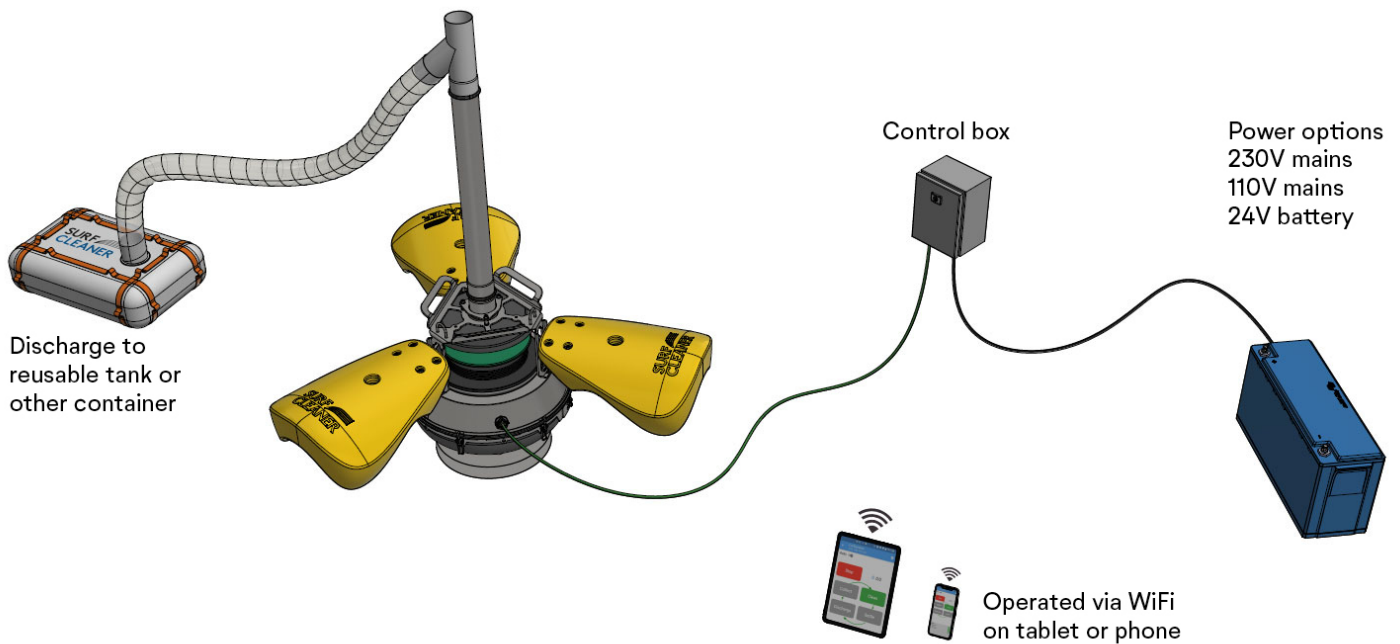

# A fully self contained system for removal, separation and recovery of pollution in remote locations



## SurfCleaner benefits:

- Portable, easy to move and handle by one person
- Able to handle different types of oil without adjustment, including thin sheens
- Requires no pump, no power-pack, no hydraulics, no pneumatics
- Low power operation on-grid or off-grid via mains or battery
- Remote control via smartphone/tablet
- Automatic removal and separation of oil with up to 100% separation
- Can recover oil with a water content of less than 0.5%
- Separate up to 1,000 liters of pure oil per hour
- Continuous unmanned/remote operation with minimal service requirements
- Quiet operation, ideal for locations in noise sensitive areas
- ATEX/EX certified for Zone 0

## Portable SurfCleaner for flexible oil cleanup

The SCO 1000 is a hybrid skimmer separator designed for oil spills and oil separation in industries. Weighing 26 kg with a diameter under 600 mm in transport mode, the SCO 1000 can be handled by one person. It can be powered on- and off-grid, from mains power 110/230V or 24V battery. It is controlled remotely via smartphone/tablet. With these features, the SCO 1000 is a very versatile solution for a wide range of applications in oil spill cleanup and oil separation.

## SurfCleaner – a complete Hybrid Skimmer Separator solution

A simple yet effective solution for removing a wide variety of pollution – from sheen to heavy oil, and from sludge to solids. SCO 1000 is an energy efficient system that not only collects but separates and recovers pollution from the water surface. It is simple to deploy, run and maintain.

The SurfCleaner technology is based on gravimetric separation, collecting both the carrier fluid and floating pollution – with a separation capacity of up to 1,000 liters of oil per hour.

## Advanced yet simple

The SurfCleaner is ingeniously simple. The patented collection and separation system has been developed into a fully automatic, self-adjusting solution consisting of only two moving parts. The separated oil is discharged into an external floating tank or other container, thus reducing the disposal costs due to the low water content.

The SurfCleaner products have been developed through years of extensive research in close co-operation with customers, resulting in a highly efficient, durable and easily maintained range of products.

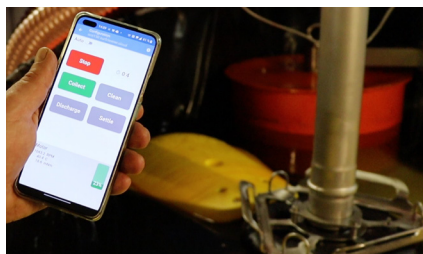

Easy to control remotely with your smartphone or tablet



# SurfCleaner SCO 1000

## – facts and information

SurfCleaner SCO 1000  
in operational mode

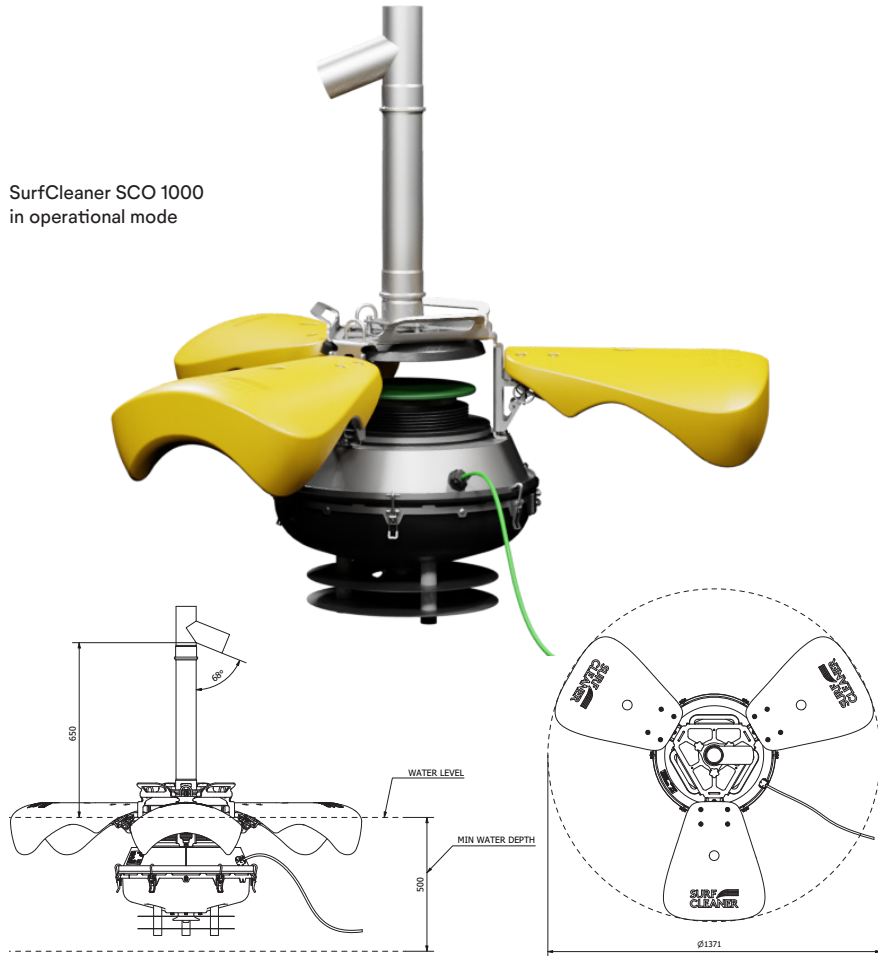

All dimensions in millimeters.

SurfCleaner SCO 1000  
in transport mode

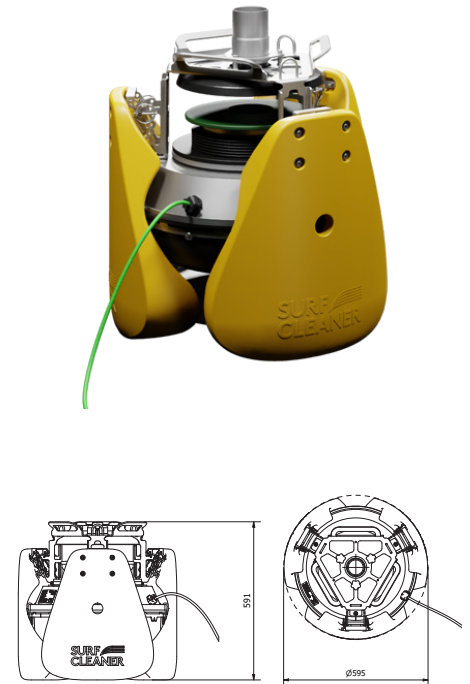

## SurfCleaner SCO 1000 – technical data

### General

Separation capacity, incl. discharge:	Up to 1,000 liters/h
Viscosity:	Up to 500 cP
Density:	0.75 to 0.92 kg/liter
Layer thickness:	> 0.1 µm
Maximum flow discharge:	7,000 liters/h
Material:	Stainless steel, Aluminum, Polyamide (Nylon), Polyethylene, Polyurethane, Nitrile Rubber
Temperature limit – parts in air:	0 to 50° C
Temperature limit – parts in liquid:	0 to 40° C (Higher temperatures on special order)

### Dimensions

Minimum depth:	500 mm
Operational diameter:	1 371 mm
Transport dimensions (Ø x h):	595 mm x 591 mm
Weight:	26 kg
Discharge pipe diameter:	75 mm

### Power and control

Power:	< 20 W average, one-phase, 120/230 V, 50/60 Hz, < 2 A
Control system:	Remote via smartphone/tablet (rugged industrialized tablet included)
Connection cable length:	10 m
Mains cable length:	10 m
Connectivity:	WiFi, Ethernet, 3G, 4G
Protocols:	MQTT, Modbus TCP

### Options

ATEX/EX:	Zone 0 certificate 
Off-grid power:	Battery, solar panel



SurfCleaner®  
is a registered  
trademark.

## About SurfCleaner

SurfCleaner designs, develops and manufactures the world's first hybrid skimmer separators for 100% removal, separation and recovery of contaminants floating on the water surface – oil, diesel, petrol, plastics, sludge, debris, microplastics, algae and more. The SurfCleaner technology is unique; by combining variations in inflow velocity and direction with gravimetric separation, the process is very efficient – keeping pollutants from accumulating on the surface and therefore help minimising greenhouse gas emissions.

The SurfCleaner makes it possible for water treatment plants to solve sludge problems and increase biogas production. We help industries to recover oil, diesel and petrol from contaminated water and reduce CO<sub>2</sub> emissions by up to 95%. We also remove oil in ports, rivers, lakes, mines and oil pits. Future models of SurfCleaner will remove plastics and algae in rivers, ports and coastal areas and make the oceans cleaner.

Customers include Sonatrach Raffineria Italiana, Ragn-Sells, Swedish Coast Guard, Preem Refinery, Esso, Exxon Mobil and Ports of Stockholm.

The principle behind the technology is Dr Stig Lundbäck's discovery of the human heart's Dynamic Adaptive Piston Pump (DAPP) functionality. He built on this DAPP technology to invent and develop the SurfCleaner – he also applied other universal laws of physics from the nature and the universe, such as gravity, equilibrium, variation in rotation velocity in the center and the periphery, different density, and more.

This makes the SurfCleaner a truly natural machine, working in concert with the laws of nature, instead of trying to combat them. The natural buoyancy sends the liquid in vertical and horizontal motion inside the body of the SurfCleaner. The SurfCleaner needs no pump, no powerpack, no hydraulics, no pneumatics. That is why the operation of the SurfCleaner is so efficient and cost-effective; we just put the forces of nature to work.

Advanced yet ingeniously simple.

### SurfCleaner's three-step technology:

#### Removal

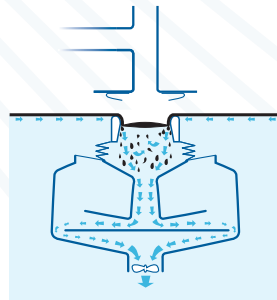

The propeller creates negative pressure, causing the water and pollution to flow into the SurfCleaner.

#### Separation

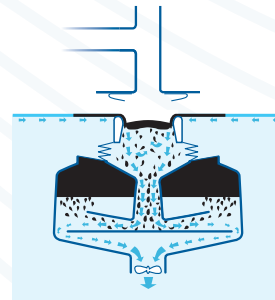

Deflection disks force the pollution and the water to the periphery. As the flow velocity drops, the pollution floats upwards while the water flows down through the outlet.

#### Recovery

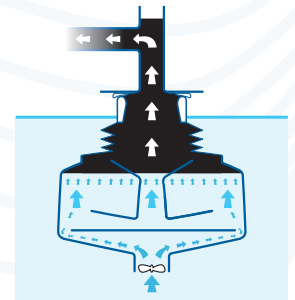

With the water acting as a piston, the pollution is discharged at the rate of up to 1,000 liters per hour into an external container. Recovered oil has a water content of less than 0.5%.

**We are  
the heart  
of water**

**SURF  
CLEANER**

SCO1000-EN-2205  
© SurfCleaner AB 2022

SurfCleaner AB  
Phone: +46 70 515 26 00  
Email: [info@surfcleaner.com](mailto:info@surfcleaner.com)  
Info: [www.surfcleaner.com](http://www.surfcleaner.com)