

Drumscreen

Design and construction

Due to its cylindrical shape the drumscreen can handle large differences in water level. The Hubert drumscreens are designed with patented A-shaped spokes resulting in high rigidity and resistance to deformation. This produces an accurate fit against pit walls, enabling filtration of particles down to 2 mm. Drumscreens are available in coated or stainless steel. All Hubert rotary drumscreens are equipped with maintenance-free slide bearings. The same applies to the ring gear and drive pinion, which are made of a special wear resistant polyamide.

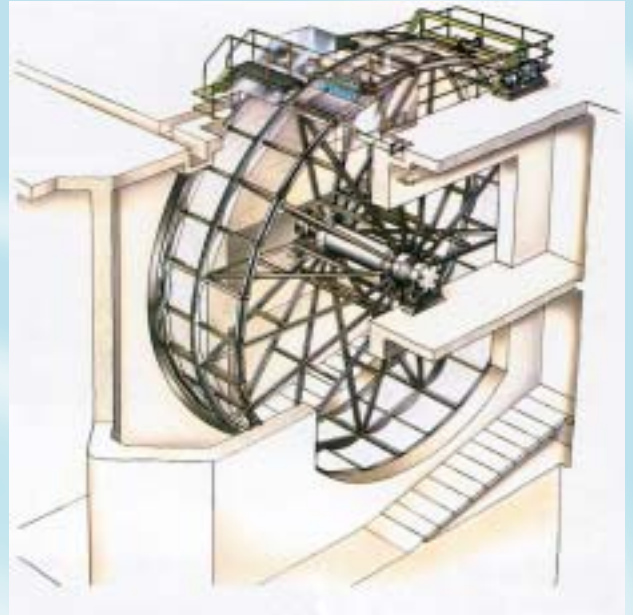

Hubert drumscreens are available for different flow patterns.

These may be:

- A-shaped spoke, see fig. 1,2,3 or 4.

Flow patterns

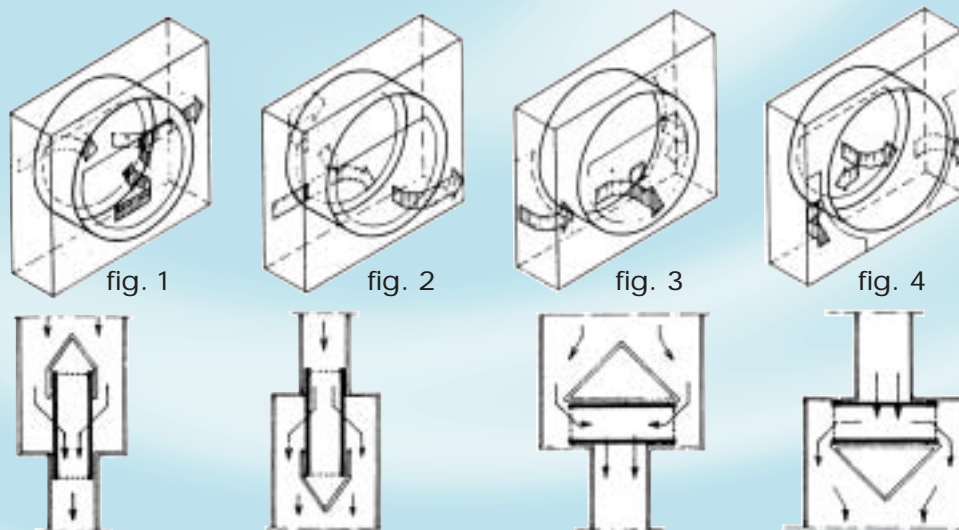

Design with A-shaped spoke

Rotary drumscreens of the A-spoke design can be supplied in diameters of 5 to 16 meters with widths varying between 2 and 5 meters. Screen mesh ranges from 2 to 10 mm at a capacity of 5,000 to 165,000 m³/h and level differential pressure of 1 m.w.c. (higher level differential pressure on special request)

Drumscreen

Advantages

- large flow capacities
- light, stable and ridged construction through A-spoke construction
- reliable
- almost maintenance free
- long lifetime (30 years and more)
- resistant to water with fine sand
- debris is removed at or above decklevel, eliminating the need for a debris pump
- less capital spares

Process Data Sheet

Diameter drum (mm)	Drumscreen Width					
	2000	2500	3000	3500	4000	mm
5000	22000	36000				m ³ /h
7000	38000	47000	58000	67000	72000	m ³ /h
9000		60000	72000	85000	97000	m ³ /h
11000			83000	100000	11700	m ³ /h
13000				119000	135000	m ³ /h
14000				137000	157000	m ³ /h
16000					165000	m ³ /h

Screen mesh 5 x 5 mm
Wire diameter 1 mm

Top of drumscreen 1500 mm above decklevel
Waterlevel in the center of the mainshaft of the drum
(50% submersion)

Offered in Australia by:



13-15 Aylesbury Street, Botany NSW 2019 Australia
(t): +61 (02) 9695 1911 www.vor-env.com

Be informed that our services are not limited to the engineering and manufacturing of our machinery's and equipment. Hubert is also your reliable partner for the erection, start-up, service and maintenance of our machinery's and equipment, worldwide.

**HUBERT
PRODUCTS**

Kooyweg 20 8715 EP Stavoren • P.O. Box 29 8715 ZH Stavoren
Tel. +31 514 684444 • Fax +31 514 682198 • info@hubert.nl • www.hubert.nl