

SWA Sand Washer in Stainless Steel



Main areas of use and features

- Efficient washing
- Re-use of washed sand
- Reduction of organic content
- Ignition loss 1-5%
- DS contents >90 %
- Decreased disposal and transportation costs
- Minimization of odour problems
- High finish guarantees a long life time

SWA SAND WASHER IN STAINLESS STEEL

Area of use

Meva Sand Washer SWA is designed to dewater and wash sand from sedimentation tanks.

In traditional sedimentation tanks, no separation of organic and inorganic materials takes place. As a result, the organic share of the material caught in the sedimentation tank often totals up to 30-80%. Meva SWA reduces the organic content in the sand to an end product with an ignition loss of 1-5%. This level is prescribed internationally.

The operation-related advantages are, apart from substantially smaller amounts of sand, a better working environment and decreased transportation and disposal costs.

Function

Water, sand and organic material (sand mix) are pumped from the sedimentation tank to the sand washer through the inlet. The inlet is placed at the top of the tank. Due to the flow conditions in the conical tank, sand and organic material are separated from the sand mix. The water is discharged through the outlet at the top of the cone.

The major part of the organic content is washed out by the integrated flushing system. The washed out organic content is discharged through the organic outlet. An agitator increases the separation during filling and washing. When the preset sand level is reached, the sand screw starts. The washed sand is dewatered during the transportation to the sand discharge.



Meva Sand Washer SWA:

- Efficient washing
- Re-use of washed sand
- Reduction of organic content
- Ignition loss 1-5%
- DS content > 90%
- Decreased disposal costs
- Minimization of odour problems
- High finish guarantees a long life time



The high finish guarantees a long life time



*End product - DS content > 90%
- Ignition loss < 5%*



Inside the Sand Washer

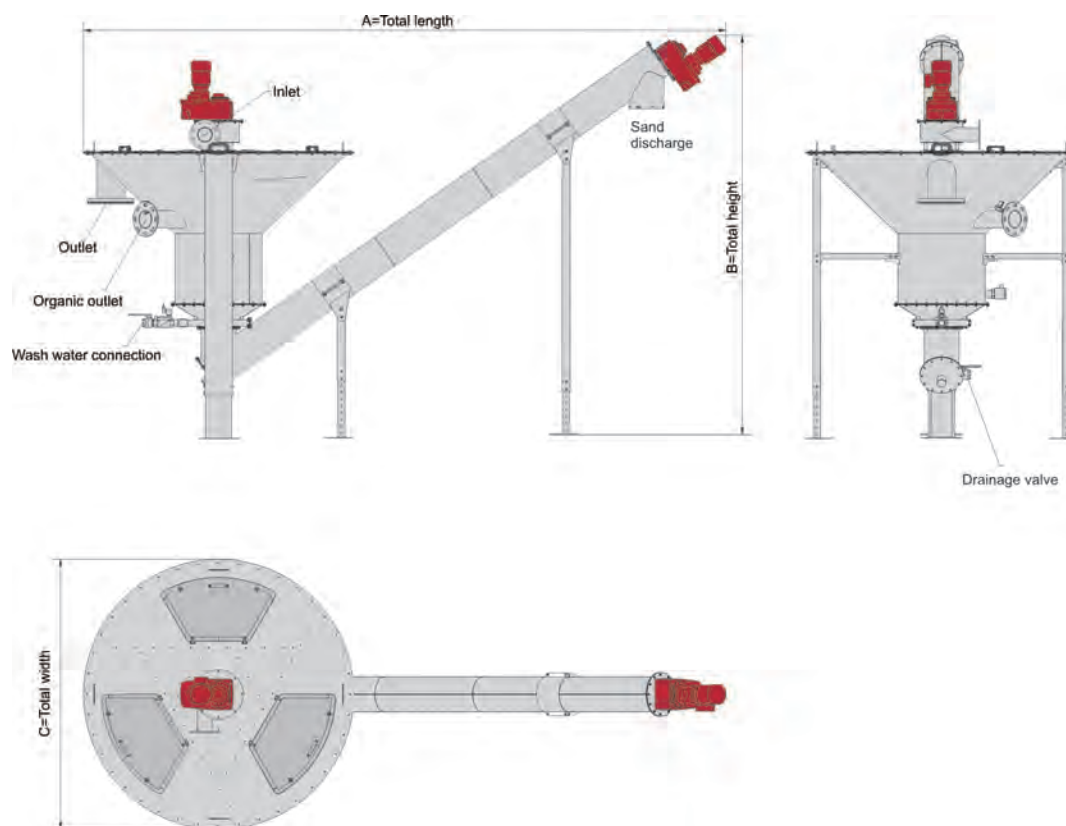

	SWA 9	SWA 12	SWA 14	SWA 21	SWA 28
Capacity sand/water (l/s)	7-9	8-12	10-14	13-21	20-28
Max sand outtake (m ³ /h)	0.3	0.5	0.3	1	1
Motor agitator/screw (kW)	0.37/0.55	0.37/0.55	0.37/0.55	0.37/1.1	1.1/1.1
Total length (mm) A	3359	4212	3614	4446	6160
Total height (mm) B	2482-2582	3198-3448	2680-2776	3204-3354	3085-3585
Total width (mm) C	1613	1900	1913	2330	2250

	SWA 12 XG	SWA 21 XG	SWA 28 XG
Capacity sand/water (l/s)	8-12	13-21	20-28
Max sand outtake (m ³ /h)	1	3	3
Motor agitator/screw (kW)	0.37/1.1	0.37/1.1	1.1/1.1
Total length (mm) A	4210	4600	5313
Total height (mm) B	3214-3414	3254-3454	3262-3762
Total width (mm) C	1900	2330	2250

Offered in Australia and New Zealand by:



13-15 Aylesbury Street, Botany NSW 2019 Australia
(t): +61 (02) 9695 1911 www.vor-env.com

ST106-En-1206