

CPS

Counter Pressure Screw in Stainless Steel



Main areas of use and features

- Superior dewatering
- Major volume and weight reduction
- Shredded screenings
- SWP + CPS achieves DS contents of 50-60%
- Decreased disposal costs
- Patented
- High finish guarantees a long life time

CPS COUNTER PRESSURE SCREW IN SS

Area of use

The combination of Meva Screw Wash Press and Meva Counter Pressure Screw results in a product optimal for incineration. The result is a product with DS content of 50-60%, shredded screenings and a superior washing effect. It gives 50% less screenings compared to washpress with a pipe system.

Function

Meva CPS is connected to the SWP by a pipe bend. The CPS creates a counter pressure during the working cycle of the SWP.

The counter pressure increases until the pre-set SWP current consumption is achieved, whereafter the CPS starts and the SWP stops. In this way, the pressure is continuously adjusted resulting in a maximum DS content.

The high counter pressure also ensures a long retention time in the press zone, which provides a superior washing effect.

At the discharge of the CPS the material is shredded, making it optimal for incineration. The CPS also works as a conveyor enabling long vertical conveying distances.

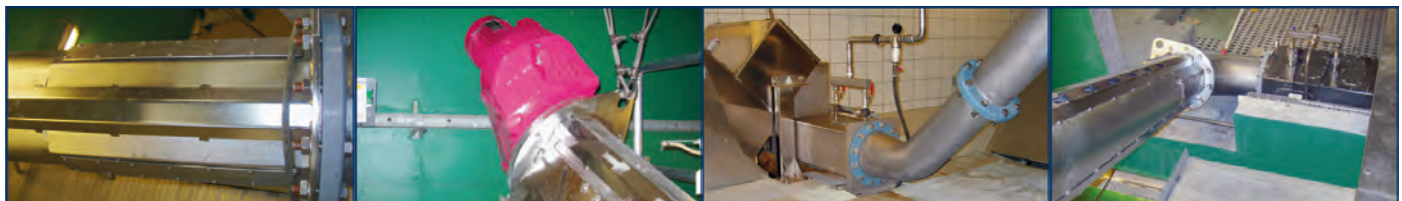

Why intensive washing and pressing?

In many countries depositing of screenings with high organic content is prohibited or connected with high cost. This will lead to demands of high DS content and screenings with high cleanliness. With Meva CPS the volume and weight reduction of screenings is significant, which leads to decreased disposal costs.

Meva Counter Pressure Screw CPS:

- Superior dewatering
- Major volume and weight reduction
- Shredded screenings
- SWP + CPS achieves DS contents of 50-60 %
- Decreased disposal costs
- Patented
- Cost savings up to 80 %
- Contributes to good working environment



Meva Counter Pressure Screw CPS



Feeding the Screw Wash Press



Screenings before washing



End product: washed, pressed and shredded screenings

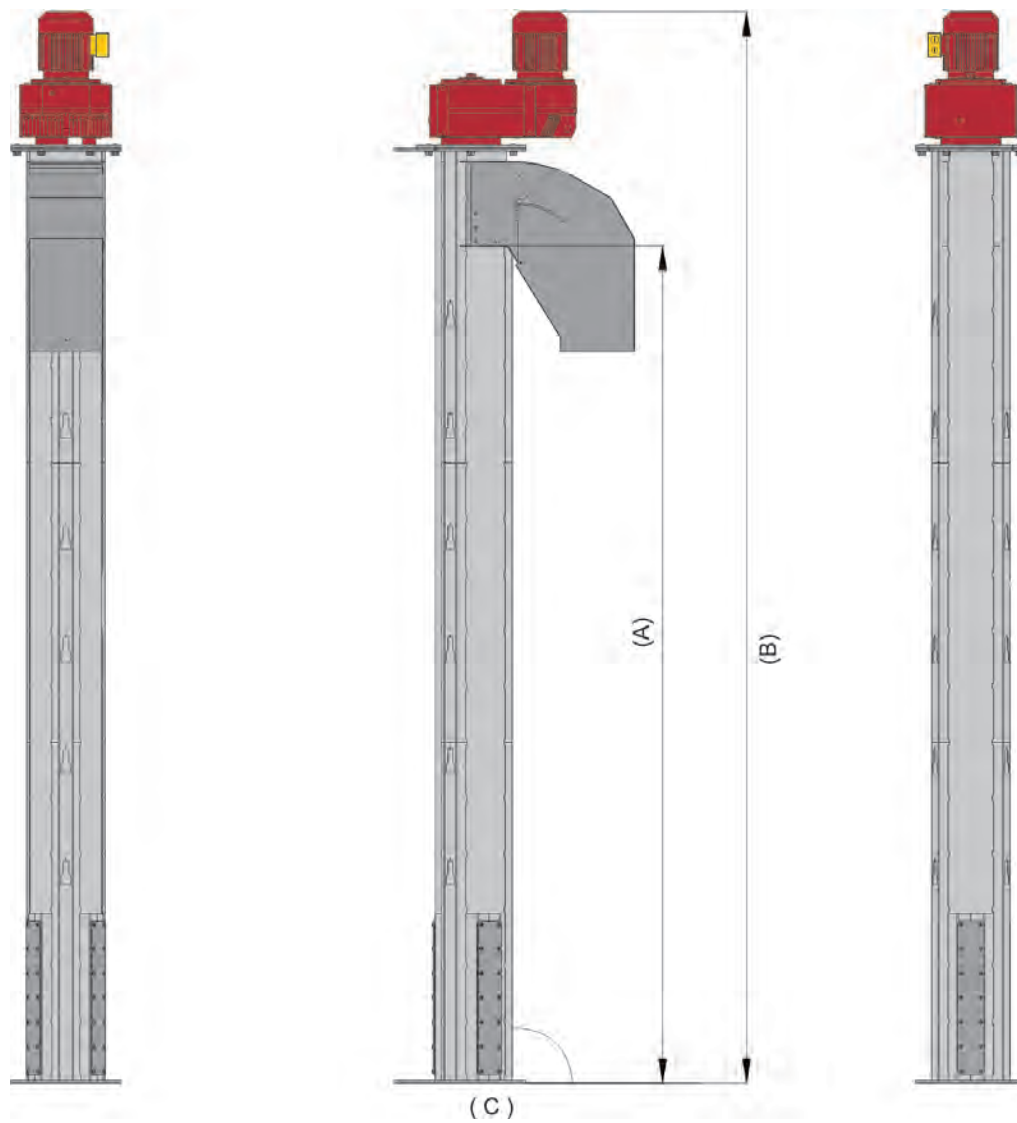

	CPS 15	CPS 20	CPS 25	CPS 30	CPS 40
Connecting flange	DN 150	DN 200	DN 250	DN 300	DN 400
Length (A)	1000-3000	1000-6000	1000-6000	1000-6000	1000-2000
Total length (B)	A + 770	A + 810	A + 840	A + 890	A + 1200
Inclination (C)	0-120	0-120	0-120	0-120	0-120

Offered in Australia and New Zealand by:



13-15 Aylesbury Street, Botany NSW 2019 Australia
(t): +61 (02) 9695 1911 www.vor-env.com

S1101-En-1206